



VTT

Coupled Analysis of Transient Scenarios (CATS)

**KYT2022-SAFIR2022 Interim Seminar
Ville Sahlberg**

CATS – modelling transient events

More reliable answers to safety requirements set in the YVL guides through refining transient safety analysis calculations

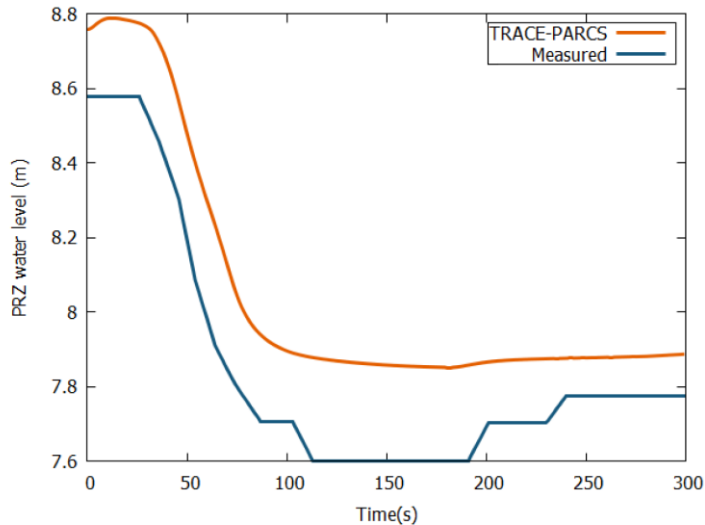

Transient analyses

Adopting CFD calculations

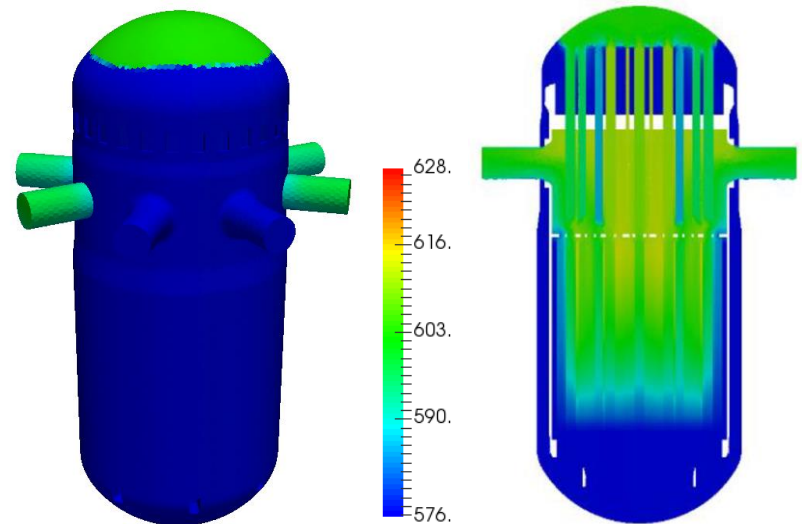

New tools

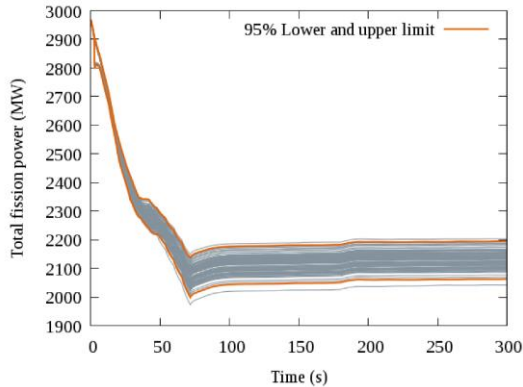
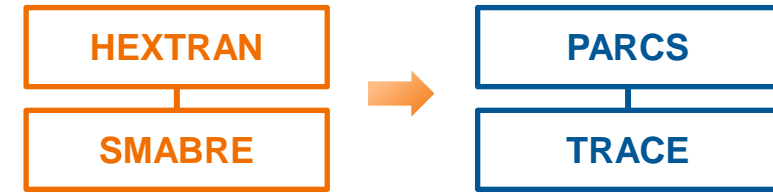

TRACE-PARCS + uncertainty and sensitivity analysis

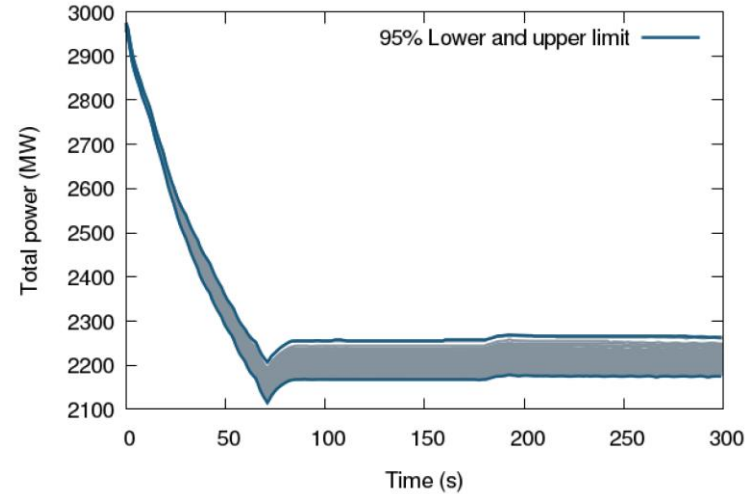

Cooperation with TRACE-PARCS developers
(VVER modelling)

Exploratory research finds new solutions...

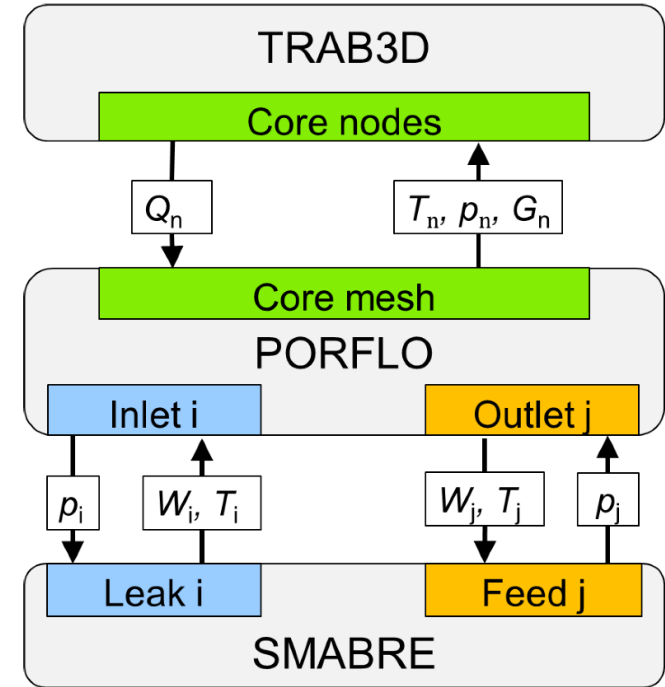
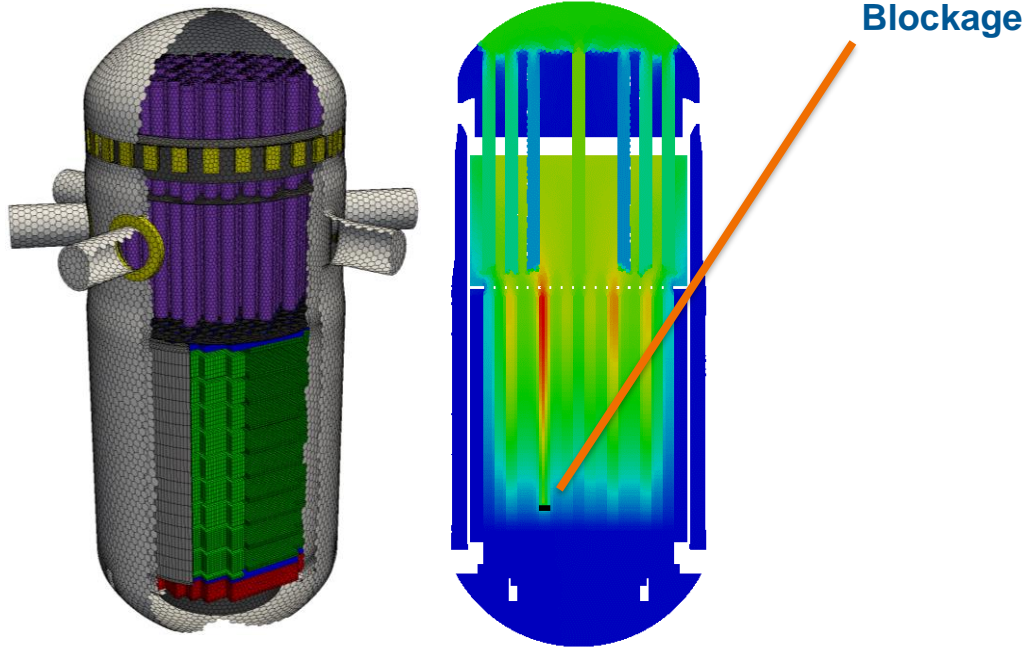

Coolant temperature in an EPR core with a blocked assembly

Exploratory research finds new solutions...

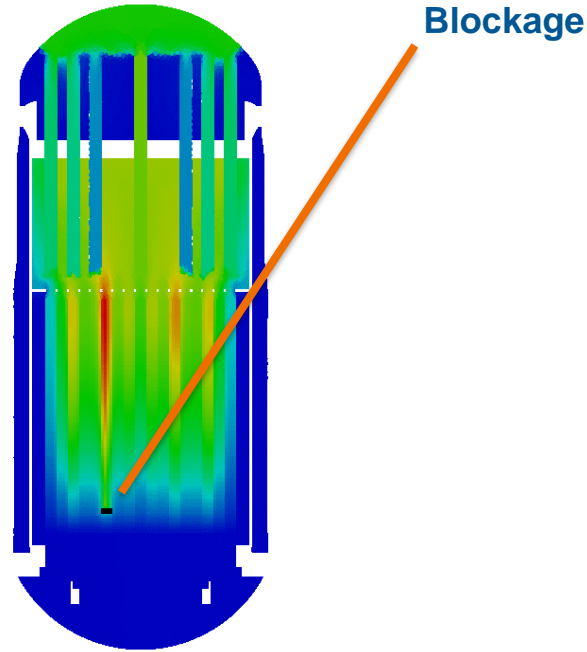
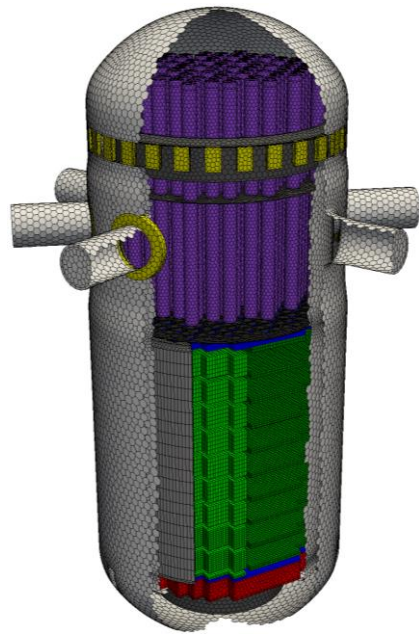

...and challenges

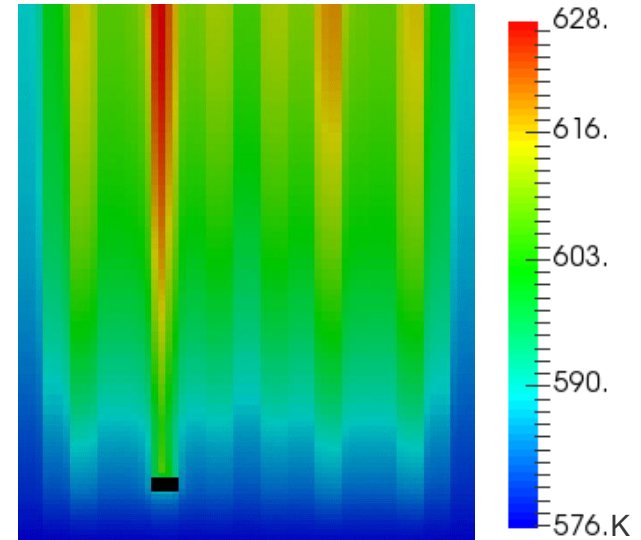

Coolant temperature in an EPR core with a blocked assembly

Refining the modelling of transient events

Tools and the expertise to use them

- Development and adoption of the next generation of safety analysis tools
- International collaboration

Research pushes on the boundaries of what really can be modelled

- Obtaining information where none was before

bey⁰nd

the obvious

Ville Sahlberg
ville.sahlberg@vtt.fi
+358 40 648 7138

@VTTFinland
@400Megawatts

www.vtt.fi